

DIY MODERN OUTDOOR SIDE TABLE

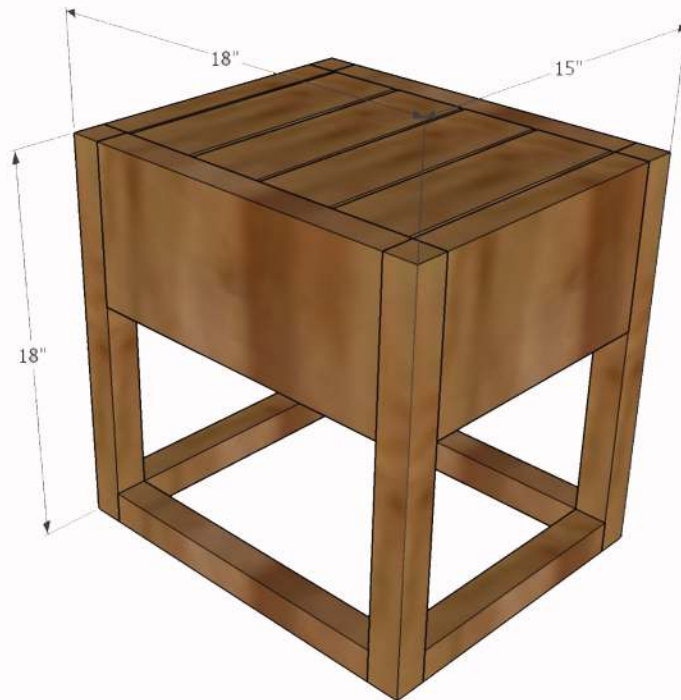

MATERIALS:

- 1 - 2X8X8
- 2 - 2X2X8
- 1 - 1X4X8
- 1 - 1X2 SCRAP PIECE 29" LONG

CUT LIST:

- 2 - 2X8 @ 15"
- 2 - 2X8 @ 12"
- 4 - 2X2 @ 18"
- 2 - 2X2 @ 15"
- 2 - 2X2 @ 12"
- 2 - 1X2 (OR OTHER SCRAP MATERIAL) @ 14 1/2"
- 4 - 1X4 @ 12"

STEP 1:

ATTACH ONE 2X8 AND 2X2 TO THE LEGS AS SHOWN. YOU WILL USE POCKET HOLES DRILLED AT 1 1/2" AND 2 1/2" SCREWS. MAKE SURE AND USE WOOD GLUE ON ALL JOINTS IN THIS PROJECT.

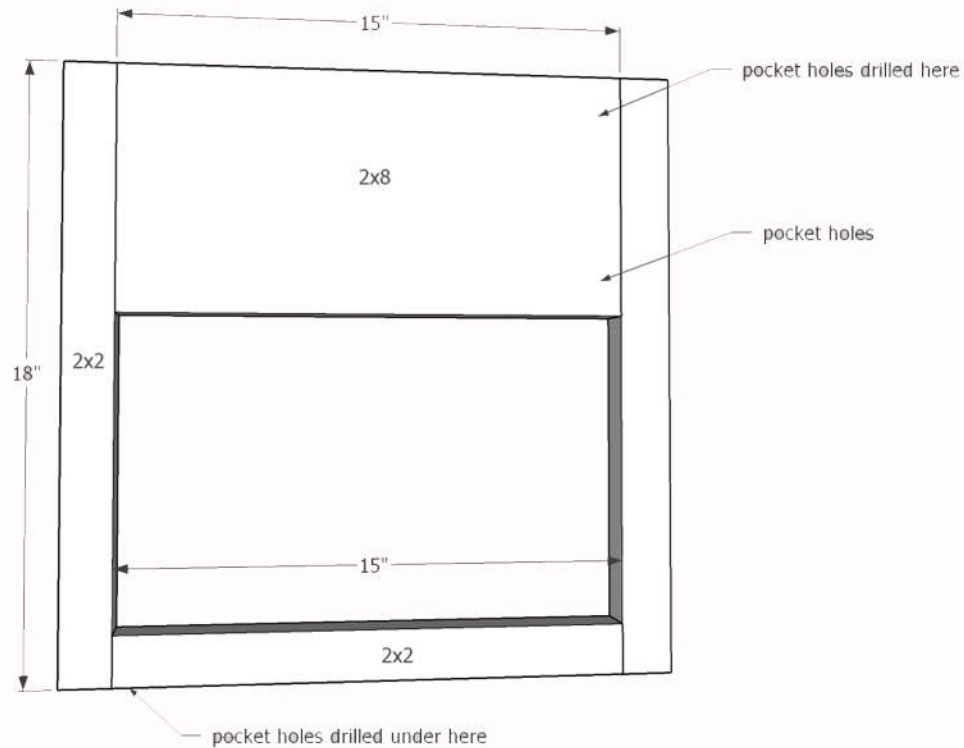

STEP 2:

ADD SCRAP 1X2 OR WHATEVER SCRAP WOOD YOU HAVE LAYING AROUND AS A SUPPORT TO ATTACH YOUR TABLE TOP TO LATER! MOVE THE BOARD DOWN 3/4" FROM THE TOP OF THE 2X8 AND BRAD NAIL (ALONG WITH GLUE OF COURSE) IT IN PLACE!

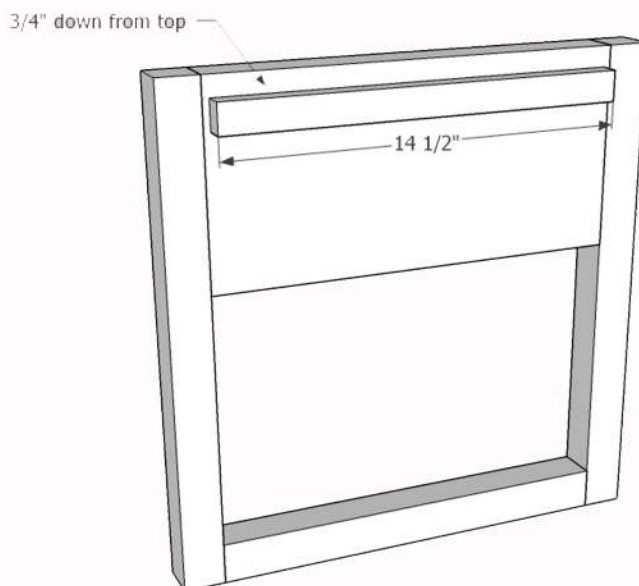

STEP 3:
CREATE A SECOND SIDE REPEATING STEPS 1 AND 2.

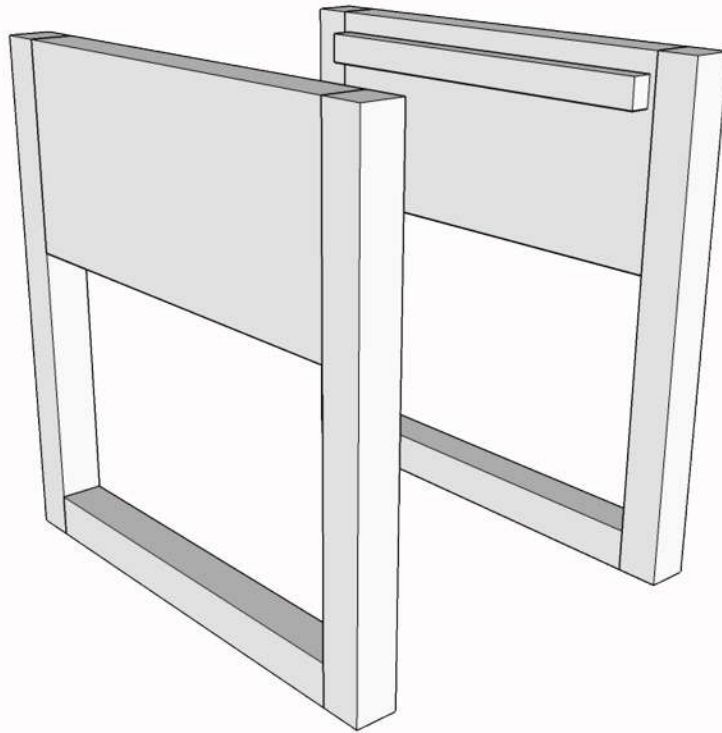

STEP 4:
ATTACH THE TWO SIDES YOU BUILT TOGETHER WITH THE 2X8 AND 2X2 @ 12". THEY WILL BE POCKET HOLED THE SAME AS PREVIOUS STEPS. (POCKET HOLES DRILLED AT 1 1/2" AND SCREWS OF 2 1/2")

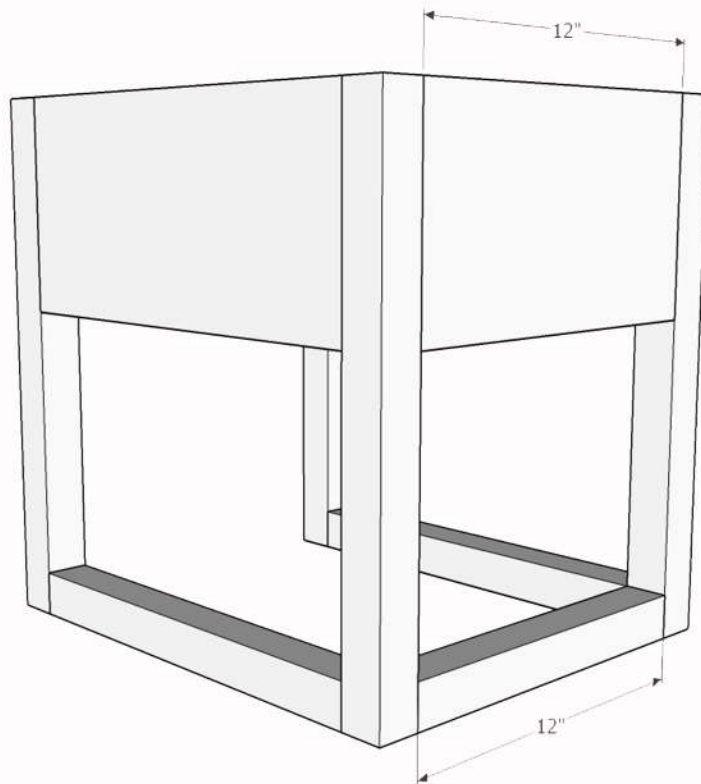

STEP 5:
ATTACH THE OPPOSITE SIDE.

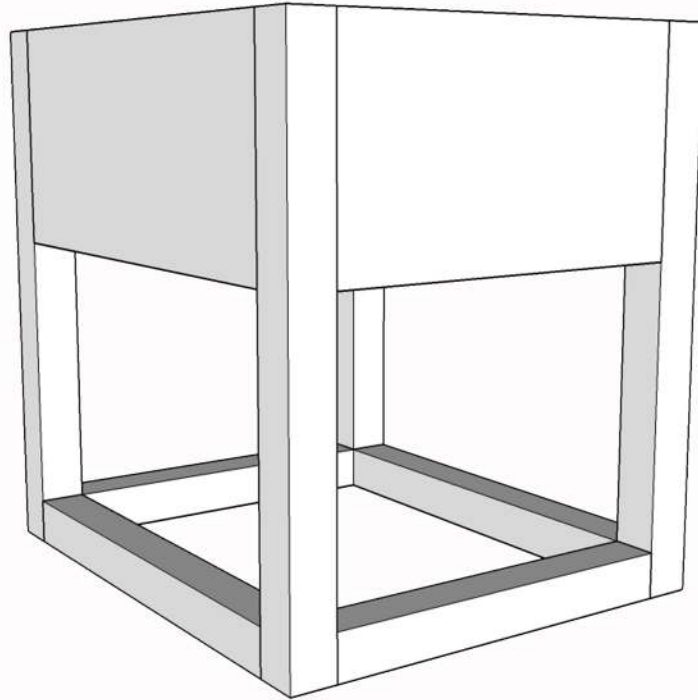

STEP 6:
GLUE THE TOP BOARDS IN PLACE. YOU CAN USE BRAD NAILS BUT I JUST GLUED THEM SO I DIDN'T HAVE TO FILL ANY HOLES!

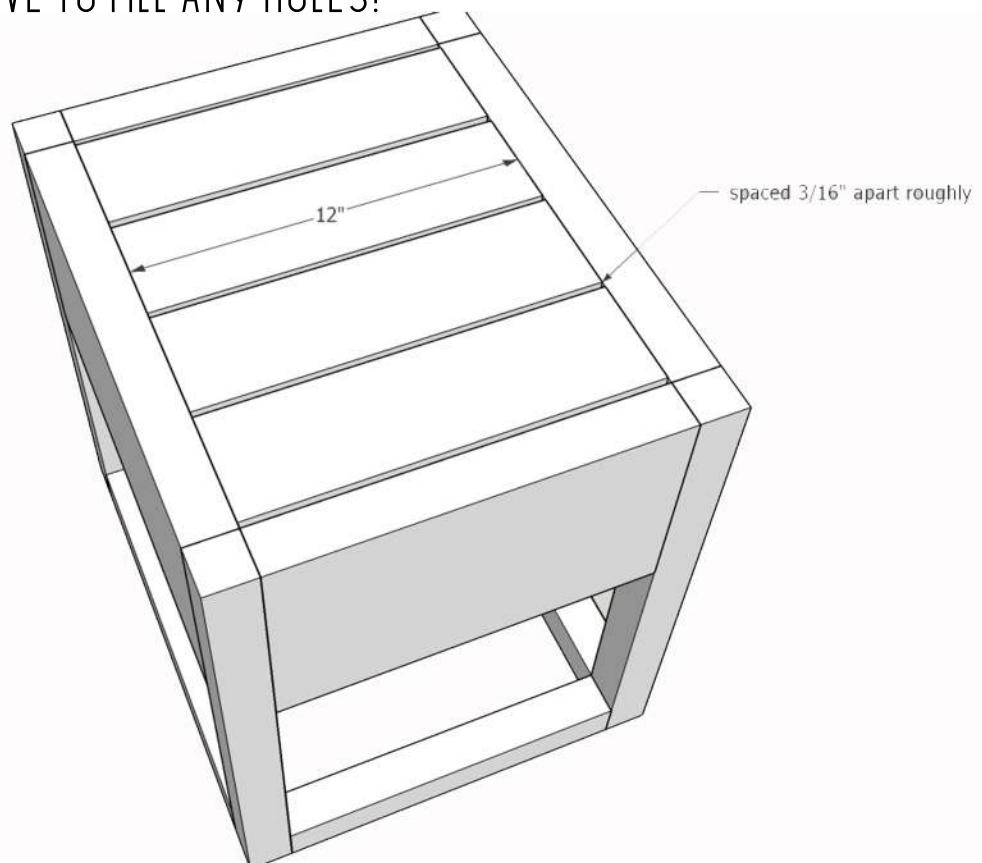

STEP 7: SAND AND FINISH HOWEVER YOU WOULD LIKE!